

# GENESIS INTERNATIONAL, INC.

## WALK-IN DUAL ZONE DEFROST CONTROL & ALARMING SYSTEM WITH LEAK DETECTION (WIC2-L)



WALK-IN CONTROL 2 ZONE WITH REFRIGERANT LEAK DETECTION (WIC2-L), Part Number 88-0358

**The Wizard Dual Zone (WIC2-L) Cooler Control System with Leak Detection** was designed to incorporate most of the control functions necessary to monitor and control the evaporators of a walk-in cooler and freezer of a supermarket, convenience store or restaurant into a compact, simple to install package. The WIC2-L utilizes the latest microprocessor technology with two row 16 character LCD back-lighted display. Plain English menu driven user interface is easy to understand and manipulate. It is equipped with a real time clock with a 5 day power loss backup. The control has as standard, an on-board 95db buzzer and a red light that will notify of an alarm. The unit is standard with 11 SPDT relays. A single control can replace the following items for Two complete Walk-In units:

Temperature Monitor, Control, Alarm  
 Door Opening Alarm  
 Defrost Controller  
 Refrigerant Leak Monitor and Alarm

Model #	Nema/IP Rating	Size Inches (mm)	Electrical Category	Pollution Protection
WIC2-L	1	12.25 x 8.75 x 3 (311 x 222 x 76)	II	2

- POWER** 25 - 250V AC, 50/60Hz, 1.0 Amp
- OPERATING TEMPERATURE** 45°F - 99°F
- OPERATING HUMIDITY** 30 - 90% RH, non-condensing
- DISPLAY** 2 lines by 16 characters, alphanumeric LCD with back light, Alarm Indication Light indicates active alarm
- KEYPAD** 5 tactile key switches  
 Scroll up, Scroll down, Select/Change, Exit, Alarm Silence/Clear
- INPUTS** Two (2) of Each:  
 Thermistor Temperature Sensor  
**SHERLOCK** sensor CMOS, IR or Electro-Chemical Sensor  
 Door Ajar Magnetic Contact Switch  
 Defrost Termination Switch/Sensor

**Control, Fan, Defrost and Alarm Relays** - These Relay Outputs are 1 Form C SPDT rated for 250 VAC and 3.15 Amp per circuit. Each relay circuit is fused with a slow blow fuse on the common leg. Outputs are screw terminal type.

**CONTROL** Two (2) Liquid Solenoid Relays  
 Two (2) Evaporator Fan Relays  
 Two (2) Defrost Heater Relays

**ALARMS** One (1) System Alarm Relay  
 Door Ajar, Low & High Temperature  
 Four (4) Refrigerant Gas Leak Alarm Relays, Two alarm levels (2 SPDT Relays per level)

### ALARM INDICATORS

**LCD DISPLAY** Cause of Alarming

**BUZZER** piezo-electric, 90db @10ft, silenceable

**FRONT PANEL LED LIGHT** Flashing red light when Control is in alarm

**STROBE LIGHT (Optional)** Mounted on top of the housing, activates during any alarm condition.

**LISTINGS** ETL, Conforms to UL Std. 3111-1 Certified to CAN/CSA C22.2 Std. No. 1010.1



**Real Time Clock with power loss backup** - The built-in electronic time clock is used for time-stamp of alarm logs. The clock has ninety nine year calendar for automatic day light saving change over and will maintains its settings for up to 5 days without power.

**Software Access "Passcode"** - The WIC2-L is passcode protected. No operating parameters can be changed without first unlocking the Control. User passcode can be changed by supervisor.

**Enclosure** - The WIC2-L comes in a metal, NEMA 1 enclosure suitable for mounting on the wall outside of the Walk-in Cooler.

**Four Key Menu System** - Consistent menu structure using only four keys. Operating parameters can be accessed and changed easily.

**Alarm History logs** - Last ten alarm logs are maintained for reviewing at any time. Each log has its own time stamp along with alarm reading.

**Standard Defrost Control** - The WIC2-L controls the Defrost of the evaporator coil, runs the Pump Down Cycle and Drip Cycle and adds 2 extra relays, for defrost, liquid solenoid, Evaporator Fan and Evaporator Heater.

**Temperature Alarming** - The WIC2-L can monitor the temperature in two separate zones (rooms). The WIC2-L

will activate its audible visual alarm and the System Alarm Relays based upon the following alarm conditions:

**High Alarm** . The room temperature must exceed the High Alarm Limit for a time period equal to or longer than the High Temp Alarm delay.

**Low Alarm** . The room temperature must be below the Low Alarm Limit for a time period equal to or longer than the Low Temp Alarm delay.

**Door Ajar Alarming** - The WIC2-L will activate its System Alarm Relay if the monitored door is opened (Door Switch is closed) for more than the Door Open Alarm Delay time. When the door is opened, the display shows the duration of the door opening in hours and minutes. To monitor more than one door, connect all door switches in parallel. (Genesis #28-0117)

**Refrigeration Leak Monitoring** - With the addition of 1 or 2 SHERLOCK Refrigerant gas sensors, the WIC2-L makes any refrigerated room or freezer room ASHRAE 15-2004 and Mechanical Code Compliant. The sensor can be gas specific Infrared (IR), Solid State CMOS or Electro-Chemical. The Leak detection feature adds 4 SPDT alarm relays for two leak alarm levels with 1 silence-able and 1 non silence-able relay for each alarm level. The WIC2-L can remotely notify systems and isolate the evaporator coil if a leak level exceeds safety limits.

## WIC2-L TYPICAL WIRING DIAGRAM

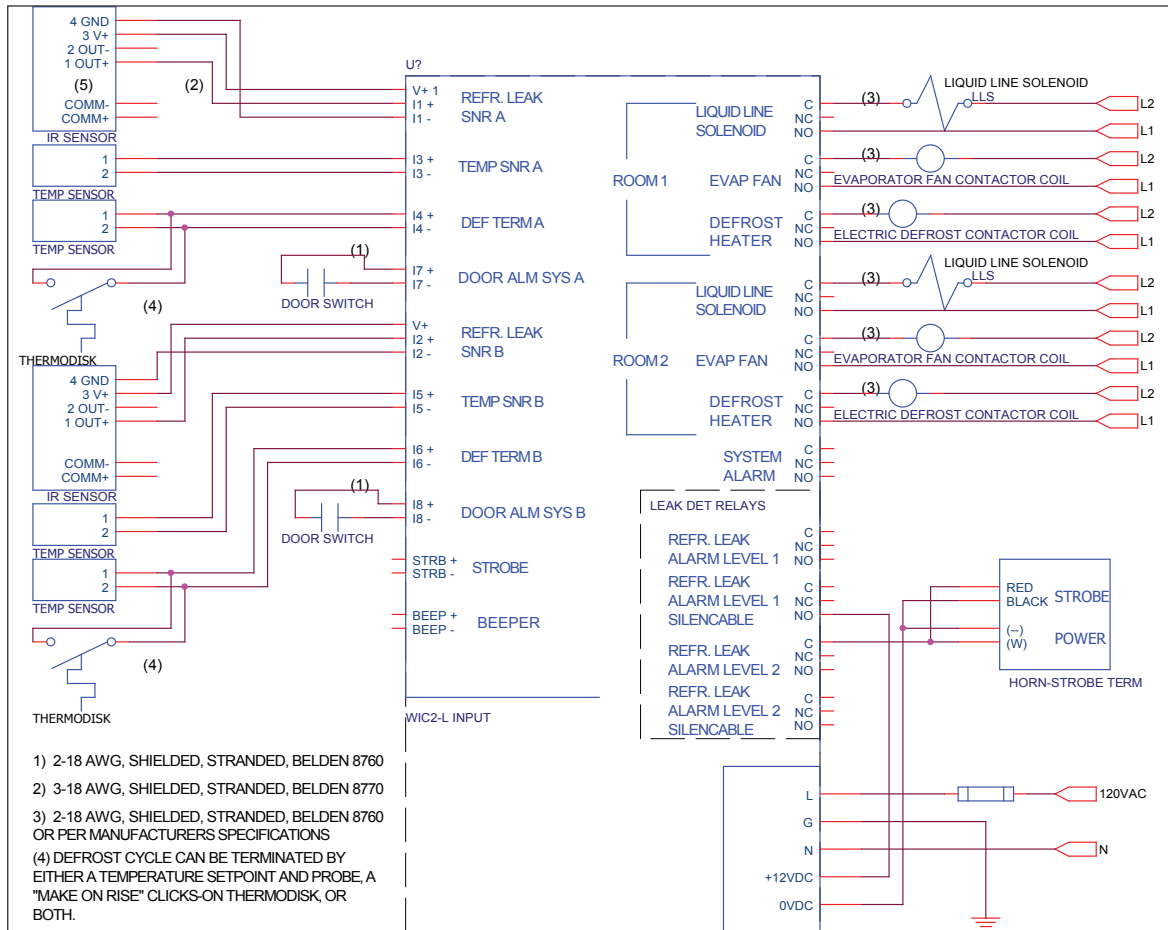

# GENESIS INTERNATIONAL, INC.

1040 Fox Chase Industrial Dr  
 Arnold, MO 63010  
 Email: mail@genesis-international.com

Tel: 636-282-0011  
 Fax: 636-282-2722  
 Web: www.genesis-international.com