



GENESIS INTERNATIONAL, INC.

Wizard

Four Zone Evaporator / Defrost Control System With Variable Speed Drive (WEC-4ZN-VSD)



4 Zone Wizard Evaporator Defrost Control (WEC-4ZN-VSD) Part #88-0718-00

The Wizard Industrial Control System with Variable Speed Drive (WEC-4ZN-VSD) was designed to incorporate the functions necessary to control up to four different valve groups in one or more large refrigerated spaces into a compact, simple to install package. A single Master / Slave WEC-4ZN-VSD can replace the following items:

- Evaporator Valve Group Status Monitor
- Multi-Function Defrost Clock
- Temperature Control
- Temperature Monitoring and Alarming
- Load Shedding Control
- System Shutdown
- Temperature Recorder
- Alarm System

NEMA 1 Compliant Enclosure - This enclosure is intended for indoor use only primarily to provide a degree of protection against contact with the enclosed equipment. The enclosure is not designed to provide protection from water or to be placed in a hazardous environment. Mount only in Pollution Level 2 environments, ie. environmentally controlled offices, control rooms, or environmentally controlled machine rooms.

Specifications (Master & Slave)

- Dimensions** 12.0 x 9.5 x 5.0 (305 x 241 x 127) Inches (mm)
- Power** 100 to 240vac, 50/60 hz, 2.5 Amps
- Inputs** Up to Three (3) NTC Thermistor Sensors, Per Zone
Three dry contacts -- *Force Defrost, Shutdown, Load Shedding.*
- Outputs** Fourteen (14) SPDT, 1 Form C, 250V AC, 5.0Amp relays for Zones 1 and 2 Master Control. Fourteen (14) Relays for Zones 3 & 4 Slave Control
- VSD Control** Variable Speed Drive - 4-20mA Output for Fans, Compressors, etc. One (1) per zone
- Alarms** System Alarms (2 relay)
Low & High Temperature
Termination Failure / Coil Recovery
- Display** 2 lines by 20 characters
Alphanumeric LCD with back light.
Evaporator Control Status LEDs -- indicates Control Operating Status of Evaporator Controls Circuits
Alarm Status LEDs -- indicates Alarm Status
- Keypad** 5 tactile pushbuttons: Scroll up, Scroll down Select/Edit/Change, Force Defrost Start/Advance
- Alarm Indicators**
 - LCD** Name, description, and current reading of alarming sensor
 - Buzzer** piezo-electric, 90db @10ft, silenceable
 - Status LED** Two on front panel of control. Indicates alarm status of the System Alarm
 - Optional Strobe Light** Mounted on the enclosure, activates during any alarm condition.

Listings

ETL, Conforms to UL Std. 61010-1
Certified to CAN/CSA, C22.2 Std. No. 61010-1

Warranty

15 Month Limited

WEC-4ZN-VSD 09-23-19

Temperature Control & Alarming - Each Wizard is equipped with a temperature sensor for monitoring and controlling temperature in a refrigerated room with 4 systems. Add up to 3 more temperature sensors for individual control of 4 separate solenoids. The control monitors & alarms to both high & low levels, each having its own programmed delay. The Wizard can monitor up to three independent temperature sensors for each zone, one for control, one for coil, and one for auxiliary.

Defrost Control - The Wizard is an electronic control & time clock which can operate up to 12 defrost cycles per day with three separate defrost schedules and manual defrost. The defrost methods can be gas, electric, water or off-time. In a defrost cycle the Wizard can sequence Solenoids, Valves, Fans & Heaters as required.

Defrost Termination - A Defrost Cycle can be terminated by Clicks-On Thermo-disk, Temperature Termination Sensor, Suction Pressure Switch or Time.

Electric Defrost								
Defrost Step	Step Name	Range	Relay / Valve / Circuit					
			Liquid Line Solenoid	Evaporator Fan	Suction Stop	Electric Defrost Pre-Heat Stage (Defrost #1)	Electric Defrost (Defrost #2)	Equalizer Valve
1	Normal Refrigeration		Cycling	On	Open	Closed	Closed	Closed
2	Pump Down	0-250 min	Closed	On	Open	Closed	Closed	Closed
3	Pre-Heat Cycle	0-250 min	Closed	Off	Closed	Open	Closed	Closed
4	Defrost Cycle	0-250 min	Closed	Off	Closed	Closed	Open	Closed
5	Drip Cycle	0-250 min	Closed	Off	Closed	Closed	Closed	Closed
6	Equalizing Cycle	0-250 min	Closed	Off	Closed	Closed	Closed	Open
7	Fan Start Delay	0-250 min	Open / Cycling	Off	Open	Closed	Closed	Closed
8	Normal Refrigeration		Cycling	On	Open	Closed	Closed	Closed

Hot Gas Defrost								
Defrost Step	Step Name	Range	Relay / Valve / Circuit					
			Liquid Line Solenoid	Evaporator Fan	Suction Stop	Soft Gas Valve (Defrost #1)	Hot Gas Valve (Defrost #2)	Equalizer Valve
1	Normal Refrigeration		Cycling	On	Open	Closed	Closed	Closed
2	Pump Down	0-250 min	Closed	On	Open	Closed	Closed	Closed
3	Soft Gas	0-250 min	Closed	Off	Closed	Open	Closed	Closed
4	Defrost Cycle	0-250 min	Closed	Off	Closed	Open	Open	Closed
5	Drip Cycle	0-250 min	Closed	Off	Closed	Closed	Closed	Closed
6	Equalizing	0-250 min	Closed	Off	Closed	Closed	Closed	Open
7	Fan Start Delay	0-250 min	Open / Cycling	Off	Open	Closed	Closed	Closed
8	Normal Refrigeration		Cycling	On	Open	Closed	Closed	Closed

Water Defrost								
Defrost Step	Step Name	Range	Relay / Valve / Circuit					
			Liquid Line Solenoid	Evaporator Fan	Suction Stop	Water Defrost Stage #1 (Defrost #1)	Water Defrost Stage #2 (Defrost #2)	Equalizer Valve
1	Normal Refrigeration		Cycling	On	Open	Closed	Closed	Closed
2	Pump Down	0-250 min	Closed	On	Open	Closed	Closed	Closed
3	Water Stage Cycle	0-250 min	Closed	Off	Closed	Open	Closed	Closed
4	Defrost Cycle	0-250 min	Closed	Off	Closed	Open	Open	Closed
5	Drip Cycle	0-250 min	Closed	Off	Closed	Closed	Closed	Closed
6	Equalizing Cycle	0-250 min	Closed	Off	Closed	Closed	Closed	Open
7	Fan Start Delay	0-250 min	Open / Cycling	Off	Open	Closed	Closed	Closed
8	Normal Refrigeration		Cycling	On	Open	Closed	Closed	Closed

Load Shedding / Temperature Control Setback - The Wizard System allows the user to change the Temperature Control Setpoint to a higher value in order to reduce energy demand.

Shutdown (Standby) - The Wizard can be configured to shutdown the system on a daily schedule, during off-season or maintenance periods.

Variable Speed Drive Output (VSD) - (Analog) This Output is wired through the Fan Control Relay to turn the fixed speed fan into a VSD fan output. 4 - 20mA or 0 - 10Volt (Factory Set). One per zone.

Remote Communications & Data Logging - GenCom Communications software allows access to view and change the Wizard within a facility via a PC connection. The Wizard will record up to 1500 temperature log entries into its internal memory.

Off-Time Defrost								
Defrost Step	Step Name	Range	Relay / Valve / Circuit					
			Liquid Line Solenoid	Evaporator Fan	Suction Stop	Water Defrost Stage #1 (Defrost #1)	Water Defrost Stage #2 (Defrost #2)	Equalizer Valve
1	Normal Refrigeration		Cycling	On	Open	Closed	Closed	Closed
2	Defrost Cycle	0-250 min	Closed	On	Open	Closed	Closed	Closed
3	Normal Refrigeration		Cycling	On	Open	Closed	Closed	Closed

Typical Wiring Diagram

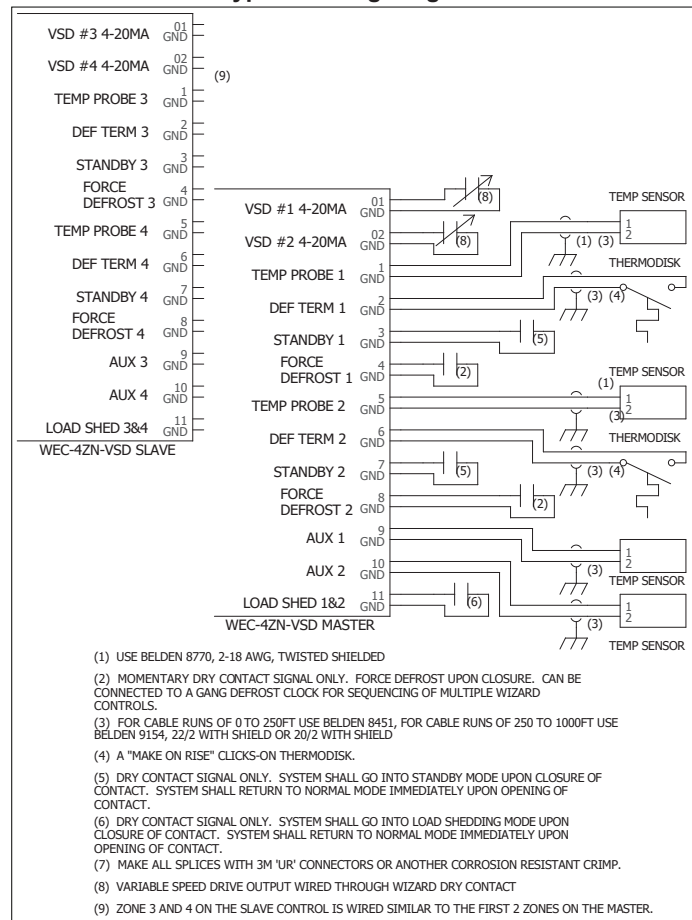

GENESIS INTERNATIONAL, INC.

1040 FOX CHASE INDUSTRIAL DR
 ARNOLD, MO 63010
 EMAIL: MAIL@GENESIS-INTERNATIONAL.COM

TEL: 636-282-0011
 FAX: 636-282-2722
 WEB: WWW.GENESIS-INTERNATIONAL.COM