



GENESIS INTERNATIONAL, INC.

Wizard

Three Zone Evaporator / Defrost Control System (WEC-3ZN)



3 Zone Wizard Evaporator Defrost Control (WEC-3ZN) Part #88-0649-00

The Wizard Industrial Control System (WEC-3ZN) was designed to incorporate the functions necessary to control up to three different valve groups in one or more large refrigerated spaces into a compact, simple to install package. A single Master / Slave WEC-3ZN can replace the following items:

- Evaporator Valve Group Status Monitor
- Multi-Function Defrost Clock
- Temperature Control
- Temperature Monitoring and Alarming
- Load Shedding Control
- System Shutdown
- Temperature Recorder
- Alarm System

NEMA 1 Compliant Enclosure - This enclosure is intended for indoor use only primarily to provide a degree of protection against contact with the enclosed equipment. The enclosure is not designed to provide protection from water or to be placed in a hazardous environment. Mount only in Pollution Level 2 environments, ie. environmentally controlled offices, control rooms, or environmentally controlled machine rooms.

Specifications (Master & Slave)

Dimensions 12.0 x 9.5 x 5.0 (305 x 241 x 127)
Inches (mm)

Power 100 to 240vac, 50/60 hz, 2.5 Amps

Inputs Up to Three (3) NTC Thermistor Sensors, Per Zone
Three dry contacts -- *Force Defrost, Shutdown, Load Shedding.*

Outputs Fourteen (14) SPDT, 1 Form C, 250V AC, 5.0Amp relays for Zones 1 and 2 Master Control. Eight (8) Relays for Zone 3 Slave Control

Alarms System Alarms (2 relay)
Low & High Temperature
Termination Failure / Coil Recovery

Display 2 lines by 20 characters
Alphanumeric LCD with back light.
Evaporator Control Status LEDS -- indicates Control Operating Status of Evaporator Controls Circuits
Alarm Status LEDS -- indicates Alarm Status

Keypad 5 tactile pushbuttons: Scroll up, Scroll down Select/Edit/Change, Force Defrost Start/Advance

Alarm Indicators

LCD Name, description, and current reading of alarming sensor

Buzzer piezo-electric, 90db @10ft, silenceable

Status LED Two on front panel of control. Indicates alarm status of the System Alarm

Optional Strobe Light Mounted on the enclosure, activates during any alarm condition.

Optional Dual Variable speed control relay, (Fans, Compressors, Etc.)

Listings

ETL, Conforms to UL Std. 61010-1
Certified to CAN/CSA, C22.2 Std. No. 61010-1

Warranty 15 Month Limited

WEC-3ZN 09-23-19

Temperature Control & Alarming - Each Wizard is equipped with a temperature sensor for monitoring and controlling temperature in a refrigerated room with 3 systems or add a second and a third temperature sensor for individual control of temperature of 3 separate systems. The control monitors and alarms to both high and low levels, each having its own programmed delay. The Wizard can monitor up to three independent temperature sensors for temperature control, coil temperature, and an auxiliary temperature for each zone.

Defrost Control - The Wizard is an electronic control and time clock which can operate up to 12 defrost cycles per day with three separate defrost schedules as well as manual defrost. The defrost can be gas, electric, water or off-time defrost. During a defrost cycle the Wizard will sequence solenoids, valves, fans & heaters as required.

Electric Defrost								
Defrost Step	Step Name	Range	Relay / Valve / Circuit					
			Liquid Line Solenoid	Evaporator Fan	Suction Stop	Electric Defrost Pre-Heat Stage (Defrost #1)	Electric Defrost (Defrost #2)	Equalizer Valve
1	Normal Refrigeration		Cycling	On	Open	Closed	Closed	Closed
2	Pump Down	0-250 min	Closed	On	Open	Closed	Closed	Closed
3	Pre-Heat Cycle	0-250 min	Closed	Off	Closed	Open	Closed	Closed
4	Defrost Cycle	0-250 min	Closed	Off	Closed	Closed	Open	Closed
5	Drip Cycle	0-250 min	Closed	Off	Closed	Closed	Closed	Closed
6	Equalizing Cycle	0-250 min	Closed	Off	Closed	Closed	Closed	Open
7	Fan Start Delay	0-250 min	Open / Cycling	Off	Open	Closed	Closed	Closed
8	Normal Refrigeration		Cycling	On	Open	Closed	Closed	Closed

Hot Gas Defrost								
Defrost Step	Step Name	Range	Relay / Valve / Circuit					
			Liquid Line Solenoid	Evaporator Fan	Suction Stop	Soft Gas Valve (Defrost #1)	Hot Gas Valve (Defrost #2)	Equalizer Valve
1	Normal Refrigeration		Cycling	On	Open	Closed	Closed	Closed
2	Pump Down	0-250 min	Closed	On	Open	Closed	Closed	Closed
3	Soft Gas	0-250 min	Closed	Off	Closed	Open	Closed	Closed
4	Defrost Cycle	0-250 min	Closed	Off	Closed	Open	Open	Closed
5	Drip Cycle	0-250 min	Closed	Off	Closed	Closed	Closed	Closed
6	Equalizing Cycle	0-250 min	Closed	Off	Closed	Closed	Closed	Open
7	Fan Start Delay	0-250 min	Open / Cycling	Off	Open	Closed	Closed	Closed
8	Normal Refrigeration		Cycling	On	Open	Closed	Closed	Closed

Water Defrost								
Defrost Step	Step Name	Range	Relay / Valve / Circuit					
			Liquid Line Solenoid	Evaporator Fan	Suction Stop	Water Defrost Stage #1 (Defrost #1)	Water Defrost Stage #2 (Defrost #2)	Equalizer Valve
1	Normal Refrigeration		Cycling	On	Open	Closed	Closed	Closed
2	Pump Down	0-250 min	Closed	On	Open	Closed	Closed	Closed
3	Water Stage Cycle	0-250 min	Closed	Off	Closed	Open	Closed	Closed
4	Defrost Cycle	0-250 min	Closed	Off	Closed	Open	Open	Closed
5	Drip Cycle	0-250 min	Closed	Off	Closed	Closed	Closed	Closed
6	Equalizing Cycle	0-250 min	Closed	Off	Closed	Closed	Closed	Open
7	Fan Start Delay	0-250 min	Open / Cycling	Off	Open	Closed	Closed	Closed
8	Normal Refrigeration		Cycling	On	Open	Closed	Closed	Closed

Defrost Termination - A defrost cycle can be terminated by clicks-on thermo-disk, temperature termination sensor, suction pressure switch or time.

Remote Communications & Data Logging - GenCom Communications software allows the computer operator to access and change the Wizard within a facility via a PC connection. The Wizard will record up to 1500 temperature log entries into its internal memory.

Load Shedding / Temperature Control Setback - The Wizard system allows the user to change the temperature control setpoint to a higher value in order to reduce energy demand.

Shutdown (Standby) - The Wizard can be configured to shutdown the system on a daily schedule, during off-season or maintenance periods.

Off-Time Defrost								
Defrost Step	Step Name	Range	Relay / Valve / Circuit					
			Liquid Line Solenoid	Evaporator Fan	Suction Stop	Water Defrost Stage #1 (Defrost #1)	Water Defrost Stage #2 (Defrost #2)	Equalizer Valve
1	Normal Refrigeration		Cycling	On	Open	Closed	Closed	Closed
2	Defrost Cycle	0-250 min	Closed	On	Open	Closed	Closed	Closed
3	Normal Refrigeration		Cycling	On	Open	Closed	Closed	Closed

Typical Wiring Diagram

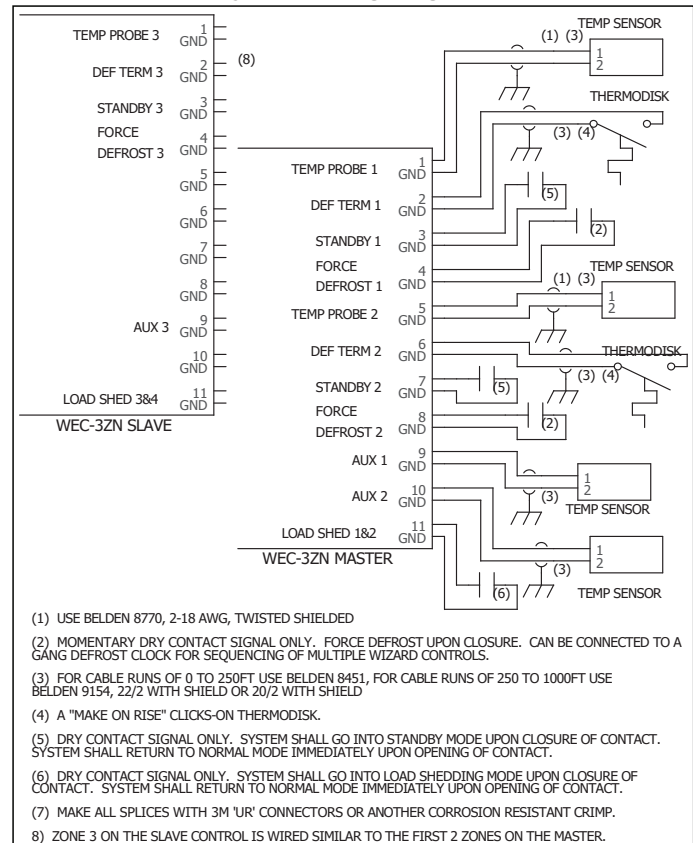

GENESIS INTERNATIONAL, INC.

1040 FOX CHASE INDUSTRIAL DR
 ARNOLD, MO 63010
 EMAIL: MAIL@GENESIS-INTERNATIONAL.COM

TEL: 636-282-0011
 FAX: 636-282-2722
 WEB: WWW.GENESIS-INTERNATIONAL.COM