



# GENESIS INTERNATIONAL, INC.

## SHERLOCK

### FAIL-SAFE REMOTE ALARM WITH PLUG IN TRANSFORMER

#### PART # 82-0127



Kit Includes:  
Remote Alarm  
9V DC, 500 mA Power Supply  
(12 V DC from Sherlock Monitor can also be used)

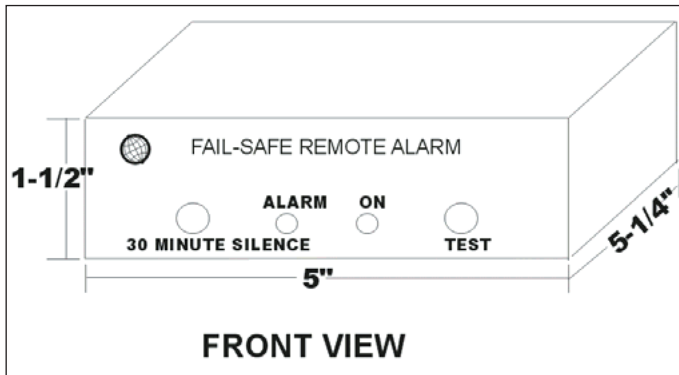

#### OVERVIEW

The SHERLOCK FAIL SAFE REMOTE ALARM will alert the user to an alarm condition. It is activated by opening up a self looping dry contact signal. The unit has a built in green "Pilot" light that is always lit to let the user know the REMOTE ALARM is working properly. The remote alarm has a built-in red LED and a 90 db buzzer to signal an alarm condition. The unit is equipped with a test button to insure the REMOTE ALARM is working properly and also a 30 minute alarm silence button. After 30 minutes the buzzer will be reactivated if the alarm condition still exists. Ideal for office use. The REMOTE ALARM easily connects to any SHERLOCK REFRIGERANT Monitor or any other normally closed alarm contact.

The REMOTE ALARM may be placed up to 5000 feet from the signal source using 18 Gauge twisted pair signal wire.

**DIMENSIONS** 5.0" x 5.25" x 1.5"  
(127mm x 133mm x 38mm)

**ENVIRONMENT** Indoor NEMA 1 Enclosure  
10°F to 120°F  
(-10°C to 50°C)

**POWER INPUT** 110 VAC to 9V - 12VDC,  
500mA wall mounted  
transformer

**SOUND OUTPUT** 90db at 2 ft

## REMOTE ALARM WIRING DIAGRAM

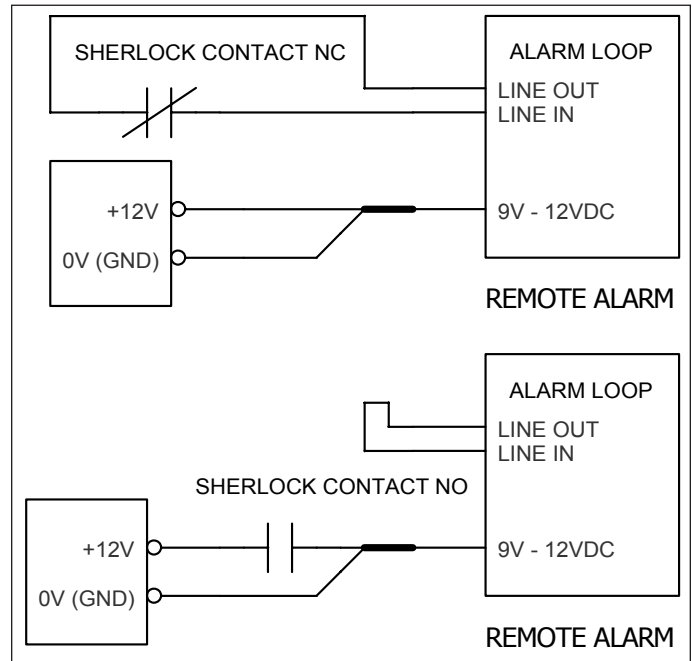
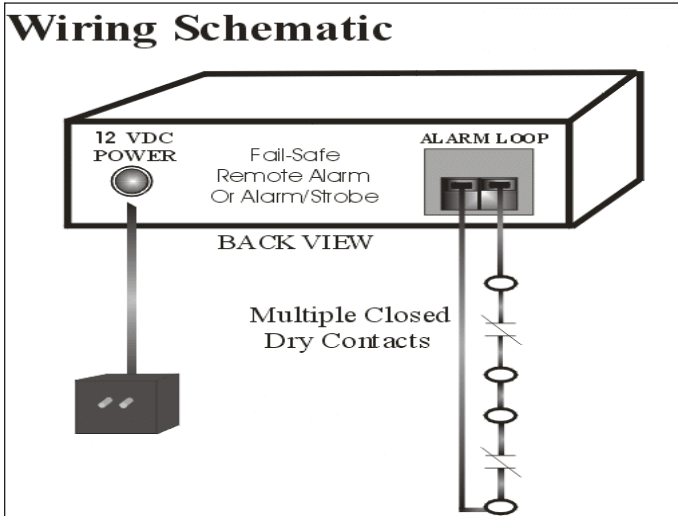

### TROUBLE SHOOTING GUIDE:

#### ***THE ALARM POWER LIGHT DOES NOT LIGHT***

Check the power plug for 9V DC - 12V DC power and verify that the transformer has power. If the transformer has failed, Call Genesis Customer Service.

#### ***ALWAYS IN ALARM***

Connect a wire across the input plug, the alarm should silence. If the alarm is silenced, the alarming circuit is open. If it does not silence when the circuit is closed, Call Genesis Customer Service.

#### ***WILL NOT ALARM***

Disconnect the input plug, the alarm should activate because the alarm circuit is open. If the alarm does not activate, Call Genesis Customer Service.



# GENESIS INTERNATIONAL, INC.

1040 FOX CHASE INDUSTRIAL DRIVE  
ARNOLD, MISSOURI 63010

PHONE: (636) 282-0011  
FAX: (636) 282-2722

WEBSITE:  
[WWW.GENESIS-INTERNATIONAL.COM](http://WWW.GENESIS-INTERNATIONAL.COM)

EMAIL:  
[MAIL@GENESIS-INTERNATIONAL.COM](mailto:MAIL@GENESIS-INTERNATIONAL.COM)