



GENESIS INTERNATIONAL, INC.

DUAL SCBA ENCLOSURE

PART NUMBER 87-0021

OVERVIEW

The Dual Deluxe Enclosure for self-contained breathing apparatus' Stores 2 complete SCBA's. Stainless steel hinges come standard to help protect against theft and will not rust. The enclosure has a durable seal around the door that protects the SCBA equipment in damp atmospheres. It has a viewing window for easy identification of contents.

Interior: 29"W x 12"D x 32 1/2"H

Exterior: 34"W x 14"D x 35"H

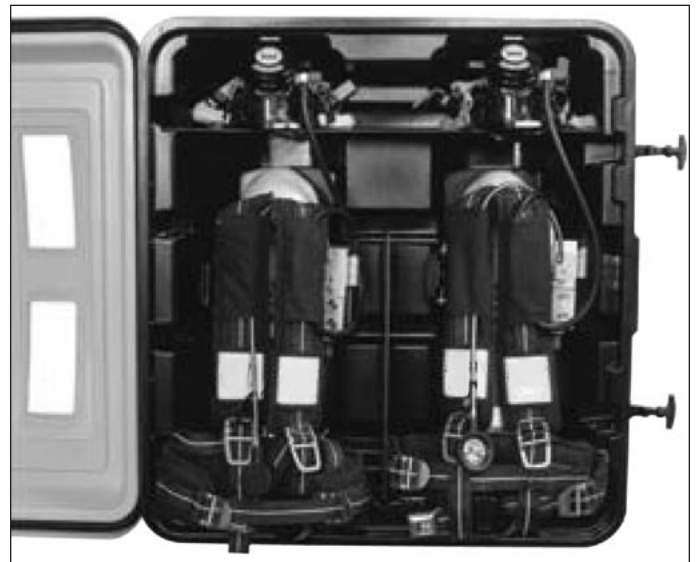

SCBA UNITS MOUNTED IN ENCLOSURE



DUAL ENCLOSURE INSIDE

Features Include:

- Bulb rubber gasket is virtually air tight.
- Storage shelf for mask.
- Permanently stores SCBA in user-ready position.
- Chemical-resistant ABS plastic case and door.
- Duallatch assembly pulls door into neoprene® rubber gasket for tight seal.
- Large viewing window for rapid contents identification of contents.
- Mask can be stored in ready-to-use position.
- Stainless steel hinges.

DIMENSIONS

Interior	Exterior
A 29"	A 34"
B 32½"	B 35"
C 12"	C 14"

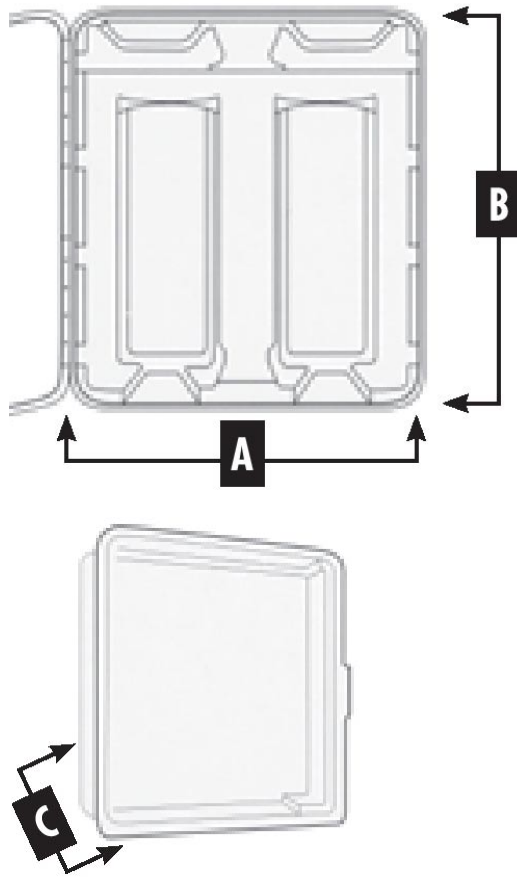

MOUNTING DUAL SCBA WALLCASE

With case laying flat position tank brackets to desired location. Mark & drill holes in the case. Mount case to solid wall, metal plate or other solid substrate.

IMPORTANT

Bolts must go through brackets into mounting surface in order to maintain rigidity in the case and support SCBA's.

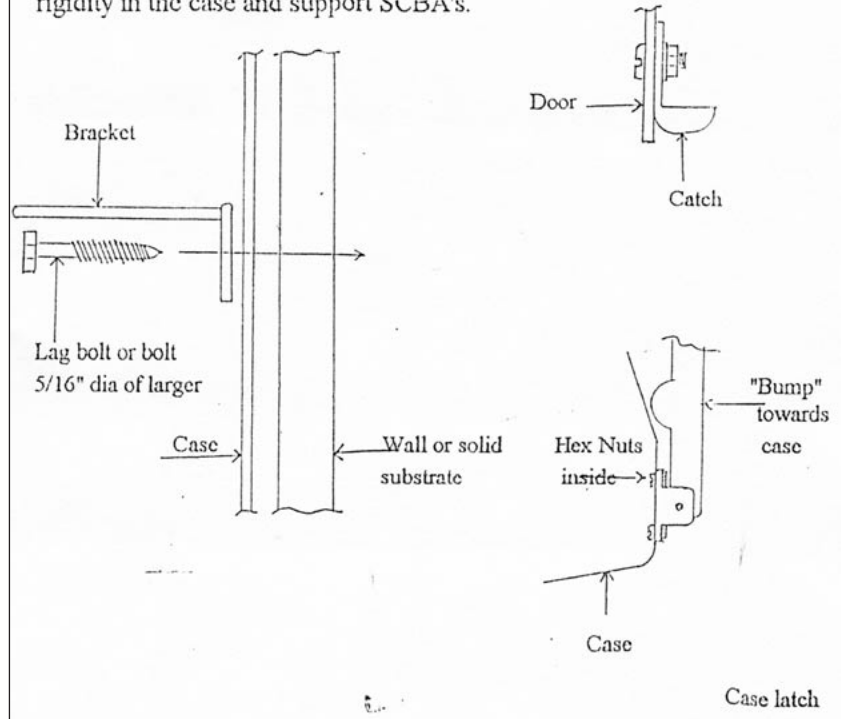

GENESIS INTERNATIONAL, INC.

1040 FOX CHASE INDUSTRIAL DRIVE
ARNOLD, MISSOURI 63010

PHONE: (636) 282-0011
FAX: (636) 282-2722

WEBSITE:
WWW.GENESIS-INTERNATIONAL.COM

EMAIL:
MAIL@GENESIS-INTERNATIONAL.COM