



GENESIS INTERNATIONAL, INC.

SHERLOCK 802 WITH OPTIONAL STROBE

REFRIGERANT GAS LEAK MONITORING AND ALARMING SYSTEM



The **SHERLOCK 802 (SHER802-S) Monitoring System** with the optional factory mounted strobe light was designed to monitor up to eight SHERLOCK Refrigerant Gas Sensors, activating up to two alarms based upon user defined alarm level setpoints. The SHERLOCK 402 is compliant with ASHRAE 15-2013 and Mechanical Code requirements for refrigerant gas monitoring.

NEMA 1 Compliant Enclosure - This enclosure is intended for indoor use only primarily to provide a degree of protection against contact with the enclosed equipment. The enclosure is not designed to provide protection from water or to be placed in a hazardous environment. Mount only in Pollution Level 2 environments, ie. environmentally controlled offices, control rooms, or environmentally controlled machine rooms.

Power Input 120/208/240vac, 50/60 Hz, 2.5 Amp

Inputs Up to 8 *Sherlock* Sensors: *Cmos, Ir*
or
Up to Seven *Sherlock* Sensors and One *Oxygen Deprivation* Sensor

Outputs Six (6) SPDT, 250VAC / 30V DC, 5.0 amp relays, Two (2) relays each, Level 1, 2 & System.
Auxiliary 12V DC Output

Optional: Auxilliary (Zone cutoff) relays (SHER802-S-R)
Optional: Modbus RS485 RTU Communications

Setback 24 Hour Time Clock
Two Dry Contact Digital Inputs

Alarms Two Alarm Levels, One Fault Level, Two SPDT Relay per Level, Fuse On Common Terminal. One relay on each alarm level can be silenceable when in alarm. Zone isolation alarm relays can activate at either level.

Operating Environment

Temperature 35°F To 120°F (2°C To 50°C)
Humidity 0 To 95% RH Non-condensing

Display 2 Line By 20 Characters
Alphanumeric Backlighted LCD display

Keypad 5 Tactile Pushbuttons
Scroll Up, Scroll Down, Alarm Silent/ Clear, Select/Edit/Change, Exit Function-Menu

Alarm Indicators

Display Name And Current Reading Of Alarming Sensor
Buzzer Built-in Piezo-electric, 90db @10ft, Silenceable
Strobe 90-110 Flashes/Min, Blue, Red, Amber

Listings ETL, Conforms to UL Std. 3111-1
CAN/CSA C22.2 Std. No. 1010.1

Warranty 15 Month Limited

<u>Model #</u>	<u>Nema/IP Rating</u>	<u>Size Inches (mm)</u>	<u>Electrical Category</u>	<u>Pollution Protection</u>
SHER802-S	1	12x9.5x5 (305x241x127)	II	2

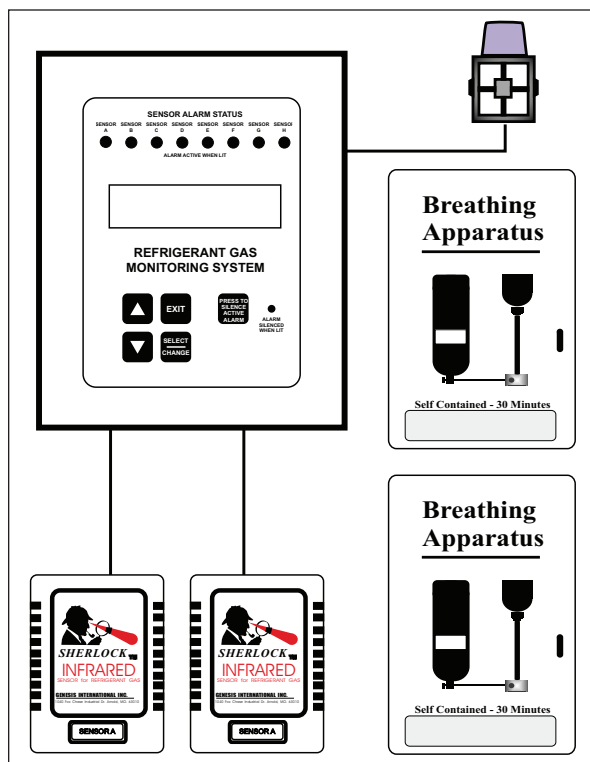

TYPICAL MACHINE ROOM INSTALLATION

Alarm Level Settings - The *SHERLOCK 802-S* allows you to set a unique Level 1 and Level 2 Alarm Setpoint for up to 8 sensors. When an Alarm Setpoint is exceeded, alarm relays activate. Each alarm setpoint has a programmable Delay of 0 to 120 minutes. Sensor readings are required to exceed an Alarm Setpoint for the programmed amount of time before the control activates the corresponding alarm relay contacts.

Alarm Indication - Alarms are logged to indicate which sensor went in and out of alarm and when. The alarm log stores the last 32 alarms. When a sensor is in alarm, an LED for this sensor on the front panel will light, the on-board beeper will sound and the display will show the activated alarm level.

Systems Sensor Open Monitoring - The *SHERLOCK 802-S* constantly monitors the wiring to the sensors. If any sensor loses communication for any reason, "OPEN" will appear on the display, the alarms will activate and the condition logged.

Setback Alarm Settings - In some instances the control may be expected to function in two different environments. The *SHERLOCK 802-S* provides a feature called SETBACK to accommodate alternate alarm conditions. SETBACK provides a secondary Alarm Setpoint and Delay. The control changes to the setback parameters when a dry contact closes (i.e. air flow switch, sail switch or timer switch) or on a daily schedule.

Alarm Relay Contacts - The *SHERLOCK 802-S* provides two fused SPDT (Single Pole Double Throw) relay outputs for each for two alarm levels and a system alarm that switch positions in the event of an alarm condition. Level 1 alarm activates the K1A and K1B relays. Level 2 alarm activates the K2A and K2B relays. System alarm activates the 3A and 3B relays. Level 2 for each individual sensor can be disabled. Relays K1B, K2B and 3B can be silenced (returned to non-alarm state) when the SILENT button on the front panel is pushed. The other alarm relays will remain active until the alarm condition is cleared. The control can be programmed so the alarm is cleared automatically when the sensor goes below the alarm setpoint (UNLATCHED) or stay on until the alarm is manually reset (LATCHED). The K1/K2 alarm level can be configured so the relays are "Energized to Alarm" or "De-Energized to Alarm", Common-Normally Open (C-NO) or Common-Normally Closed (C-NC).

Optional Auxiliary Relays (SHER402-S-R) - Optional zone isolation alarm relays (ZA - Sensor A Zone, ZB - Sensor B Zone, ZC - Sensor C Zone, ZD - Sensor D Zone). Each relay can be programmed to activate by level 1 or level 1 & 2 alarm.

Optional: Modbus RTU - This option adds an RS485 output that can communicate with a BAS.

TYPICAL WIRING DIAGRAM (EXAMPLE)

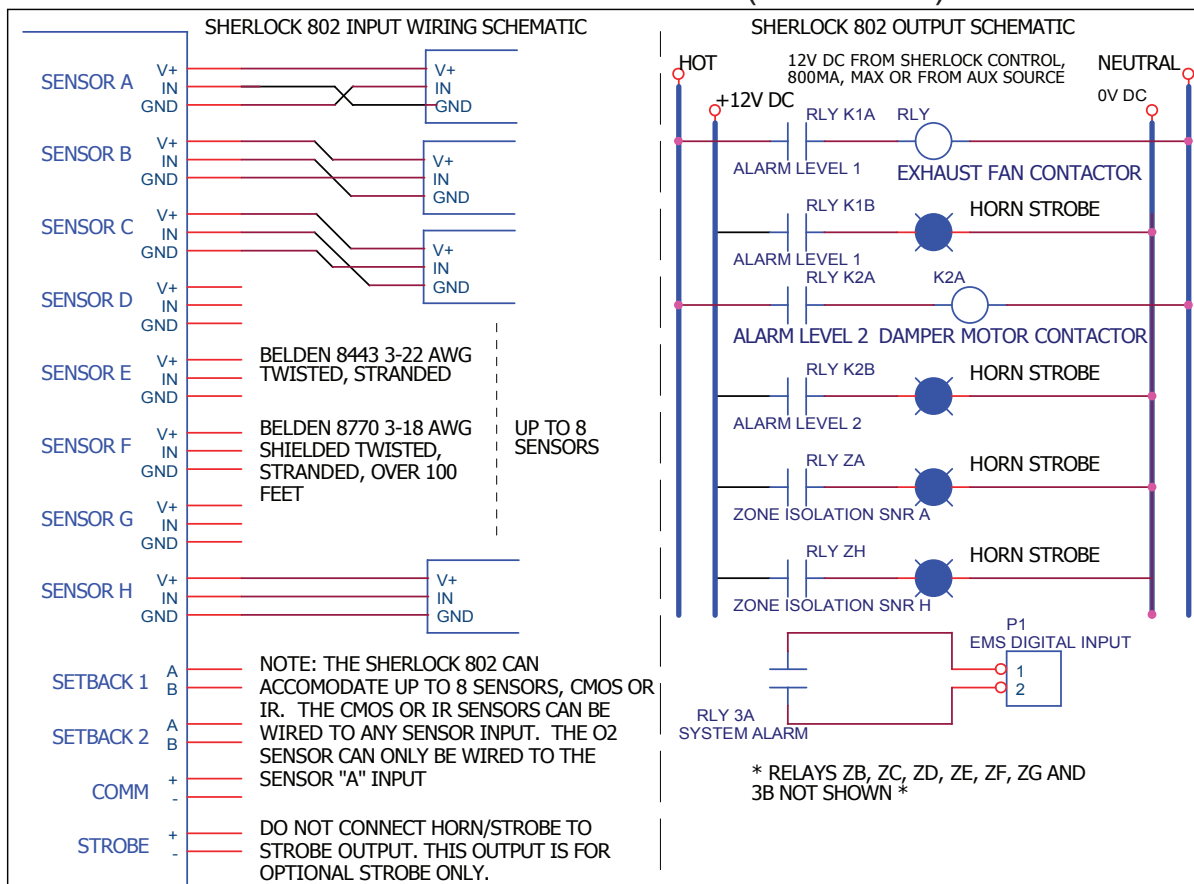

GENESIS INTERNATIONAL, INC.

1040 Fox Chase Industrial Dr
 Arnold, MO 63010
 Email: mail@genesis-international.com

Tel: 636-282-0011
 Fax: 636-282-2722
 Web: www.genesis-international.com